

Ai Ready Rack

Installation Guide

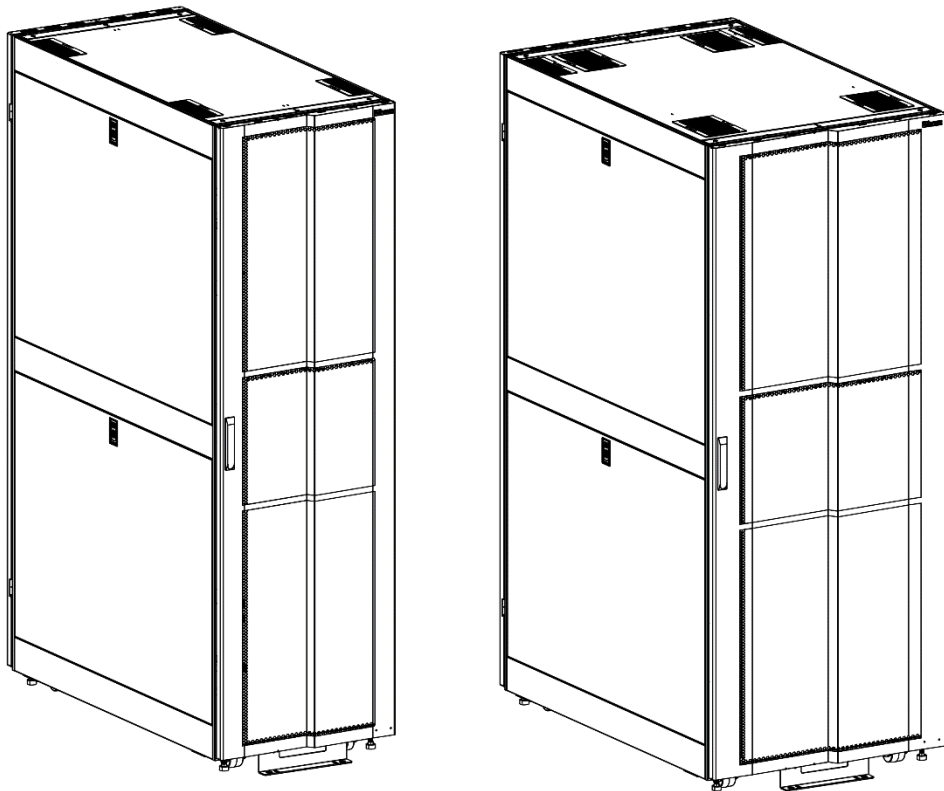

Component Identification

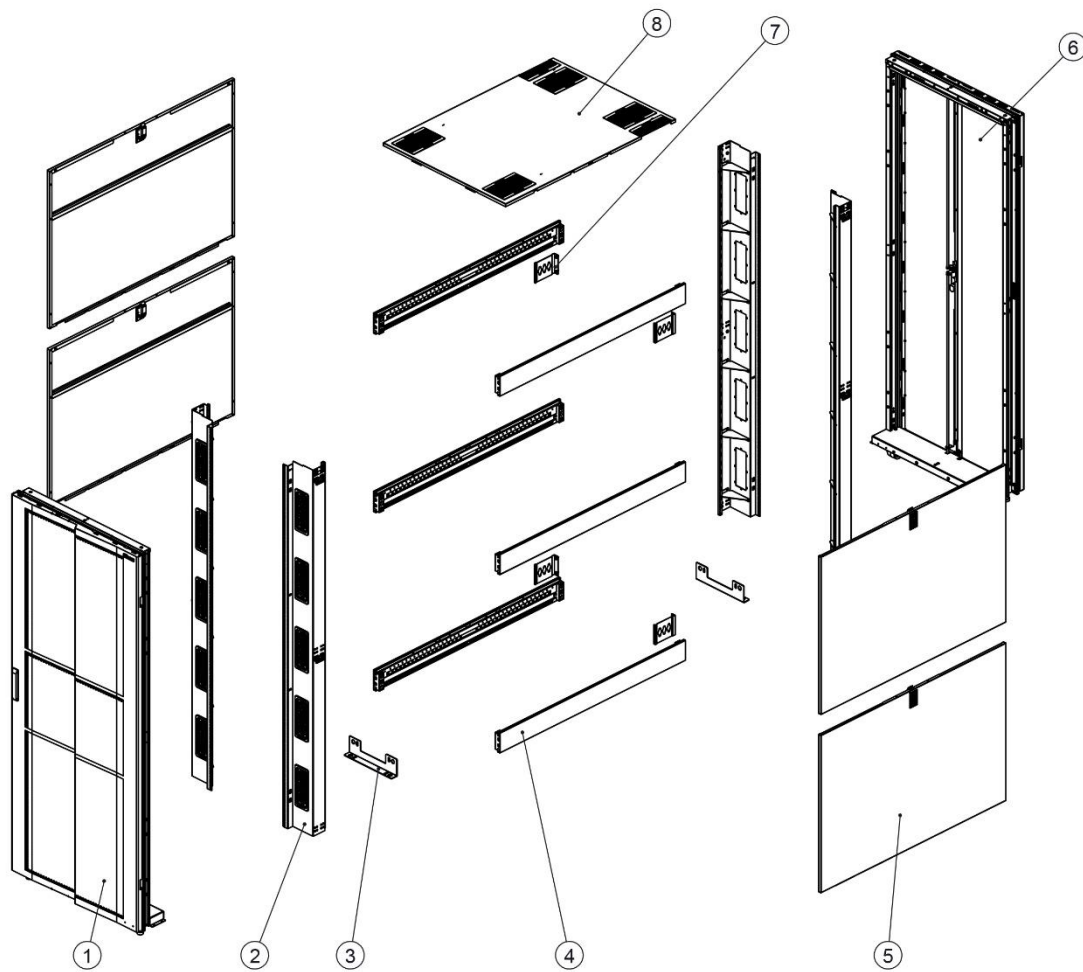

Item	DES.	QTY.
1	Front perf door with front frame	1
2	Mounting rail kit, 4pcs	1
3	L-bracket	2
4	Beam	6
5	Side panel kit, 4 pcs	1
6	Split perf rear doors/ solid sealed rear doors with rear frame	1
7	PDU short bracket	4
8	Full-depth, brush-sealed top panel	1

Preparation



Electric screwdriver



PH2 Phillips screwdriver

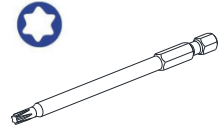

Torx screwdriver bit
(T30&T40)

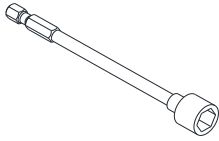

Hexagonal socket

Assemble The Cabinet

Frame

⚠ WARNING

TIP HAZARD

- For safety, hold the frame during installation.

Failure to follow these instructions can result in death and injury, or equipment damage.

- Connect Beams and Frame.

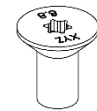
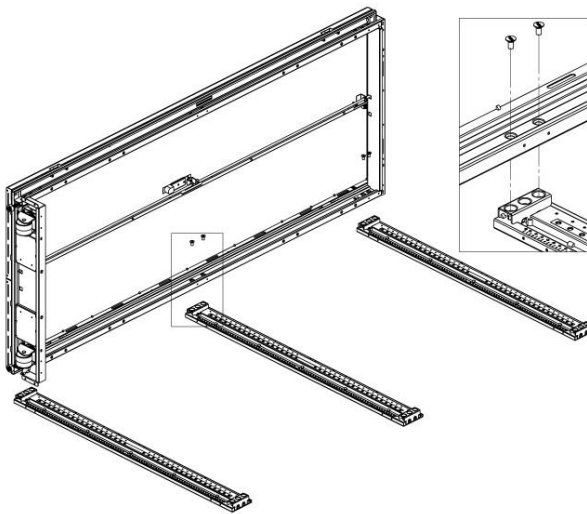

M8 Torx Countersunk Head Screw
– 24 PCS

NOTE: If encountering two configurations of frames with and without doors, install the frame without doors first and then the frame with doors.

- Reinforce the base.

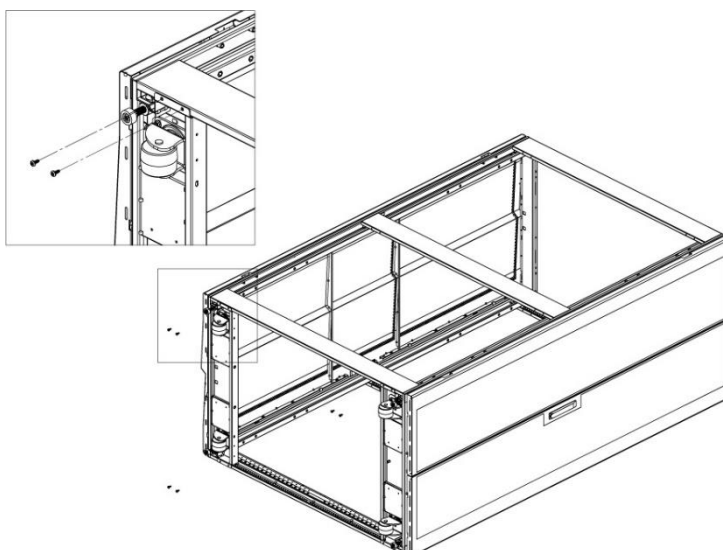

M5x12 Rounded Head with
Phillips Drive Thread-Forming
Screws – 8 PCS



- Recognize the PMAs before installation.

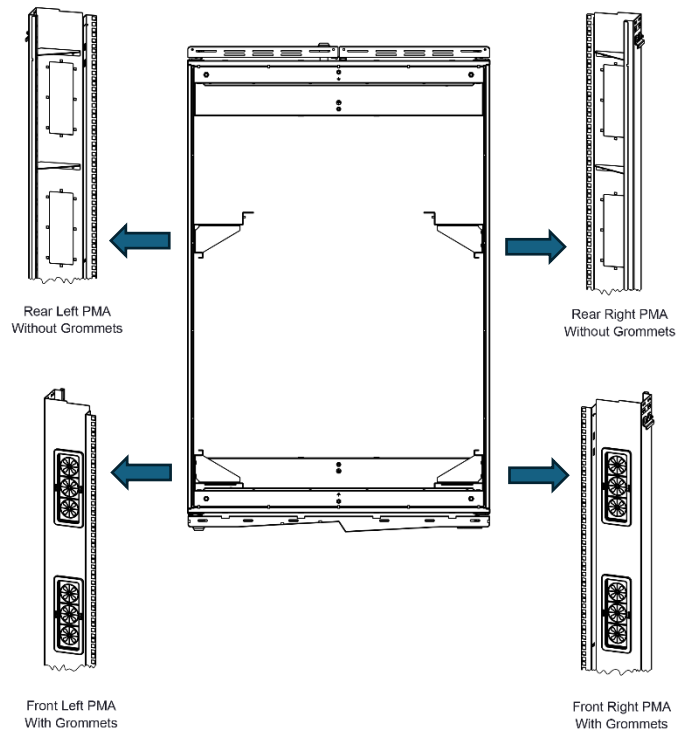

- Hang the PMAs.

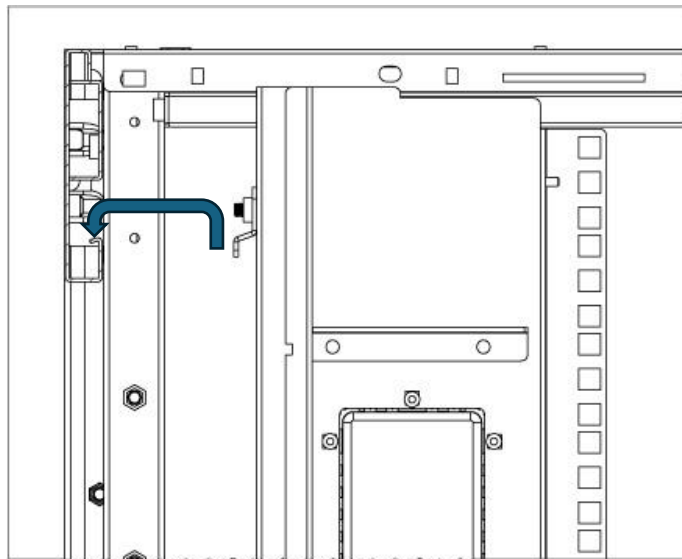

- Two PMAs which are with grommets will be located to the front side and corresponds to serial number 4.
- Two PMAs which are without grommets will be located to the rear side and corresponds to serial number 2.
- The above operations make the distance between the front and rear PMAs 29.5 in (749.3 mm).

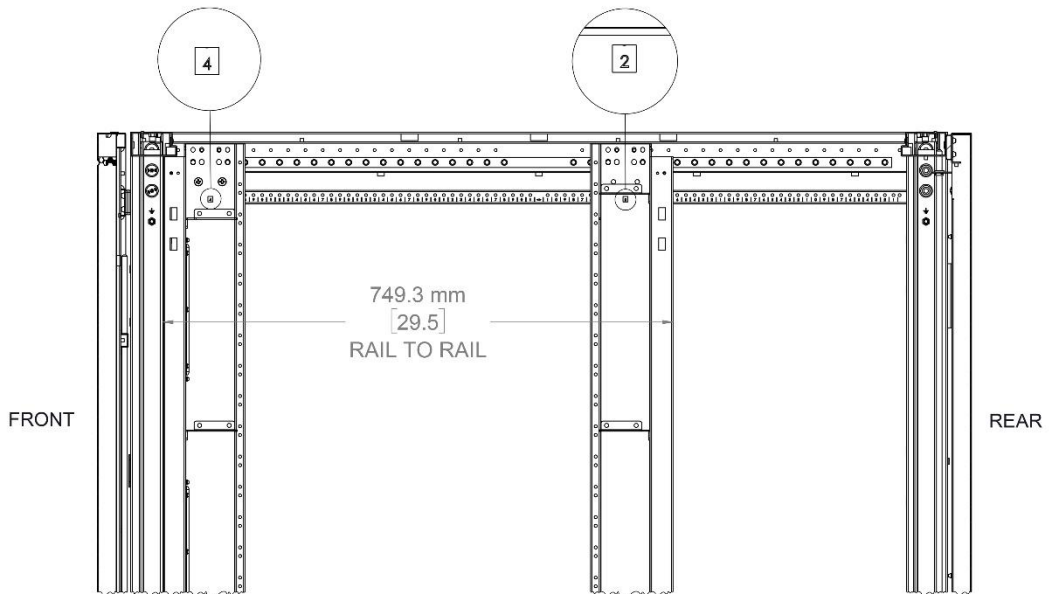

NOTE: When cable managers are required, the positions of the PMAs will change. The above is without any cable managers.

- Tighten 4 PMAs. Exist respectively in upper, middle, and lower.

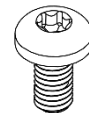
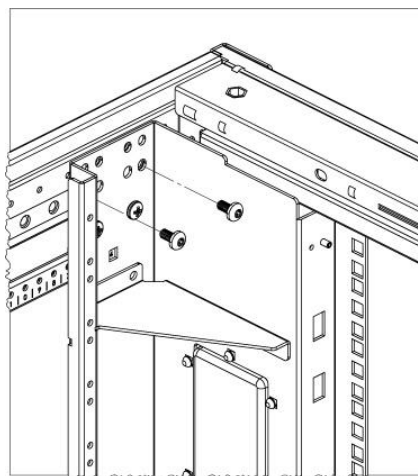

M6x16 Round Head Torx Screw
– 24 PCS

PDU Short Bracket

- Install 4 pcs PDU short brackets. And the upper and lower spacing is 61.25 in (1555.75 mm).

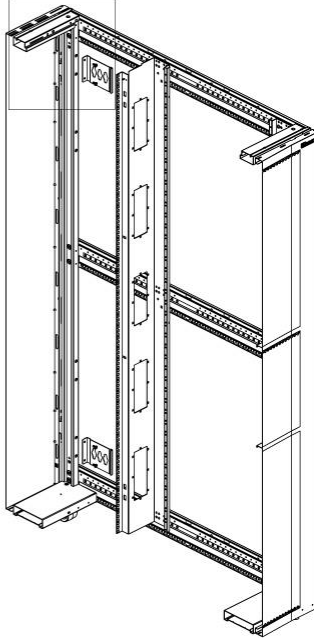
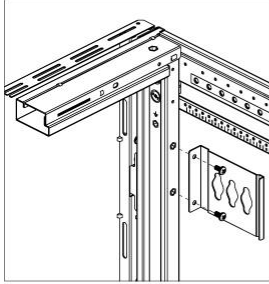

M6x12 Phillips Round Head
Screw – 8 PCS

Top Panel

X2

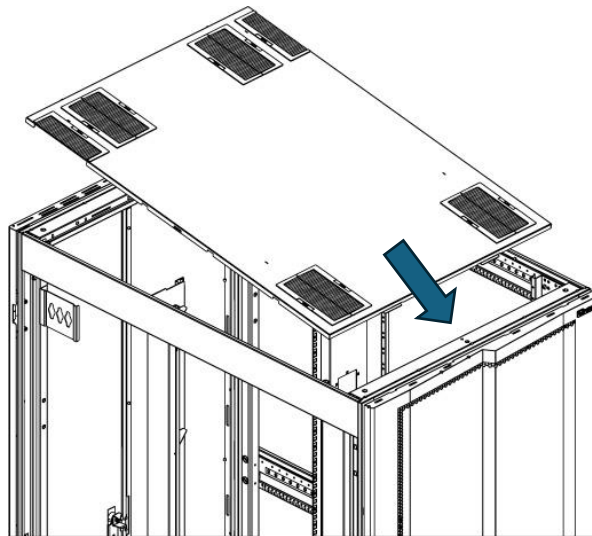
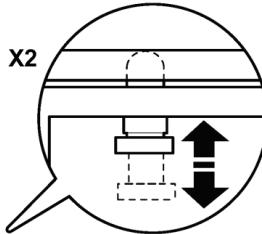

Side Panel

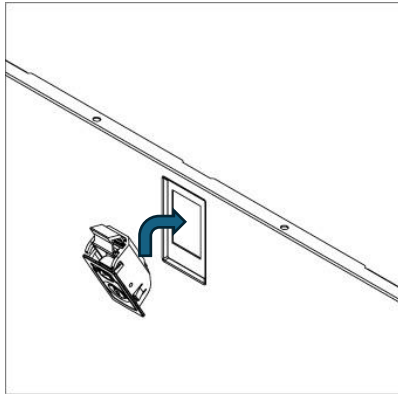

1

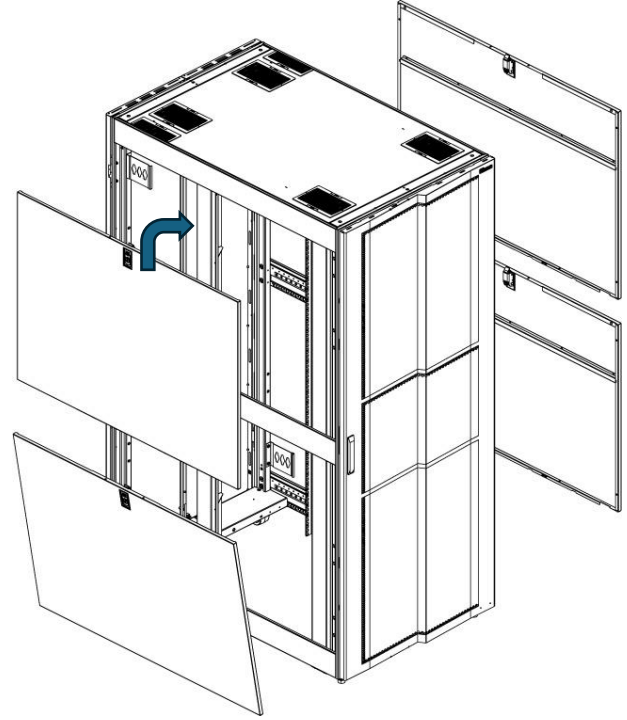

2

Packing

Fix The L-brackets

- Tie the accessory bag to the rear left mounting rail with a cable tie.
- Gently lift the cabinet onto the pallet from both sides.

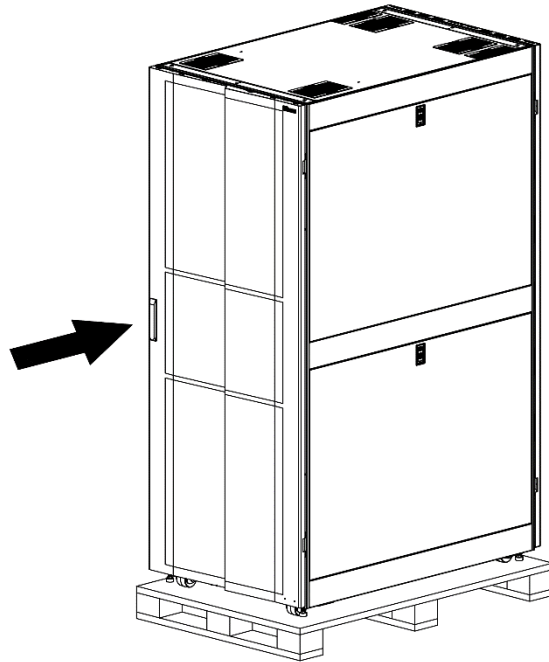

- Open the front and rear doors and install the L-brackets on the cabinet.

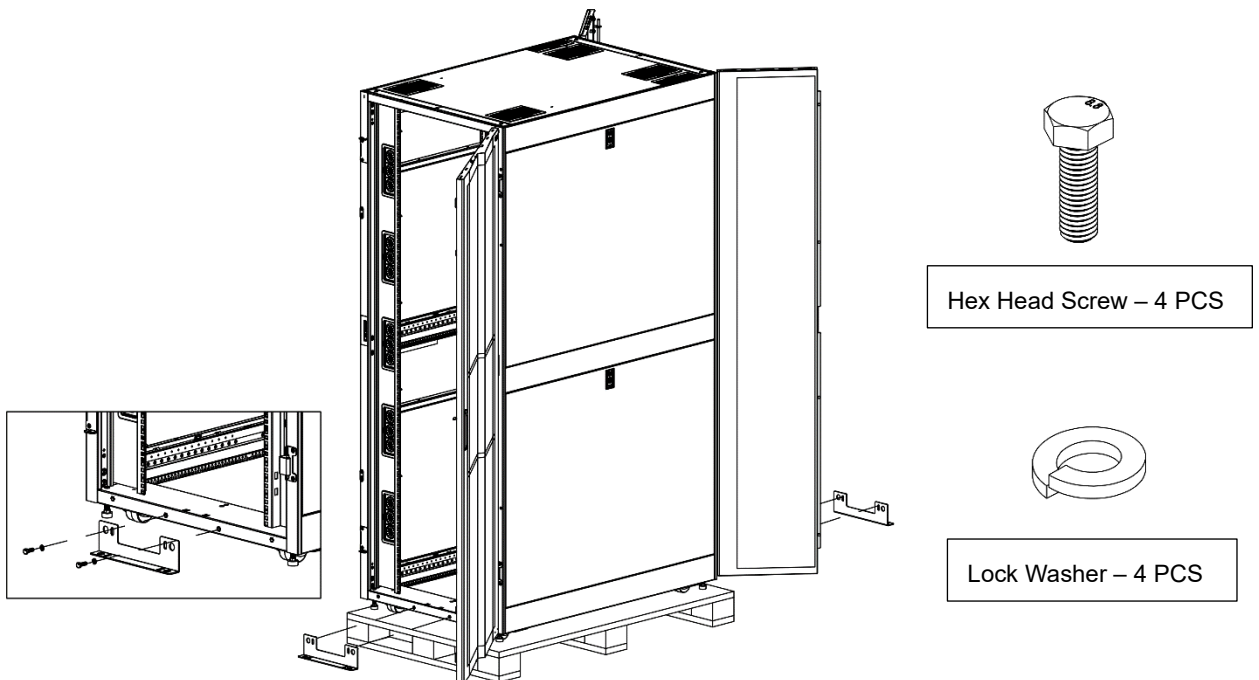

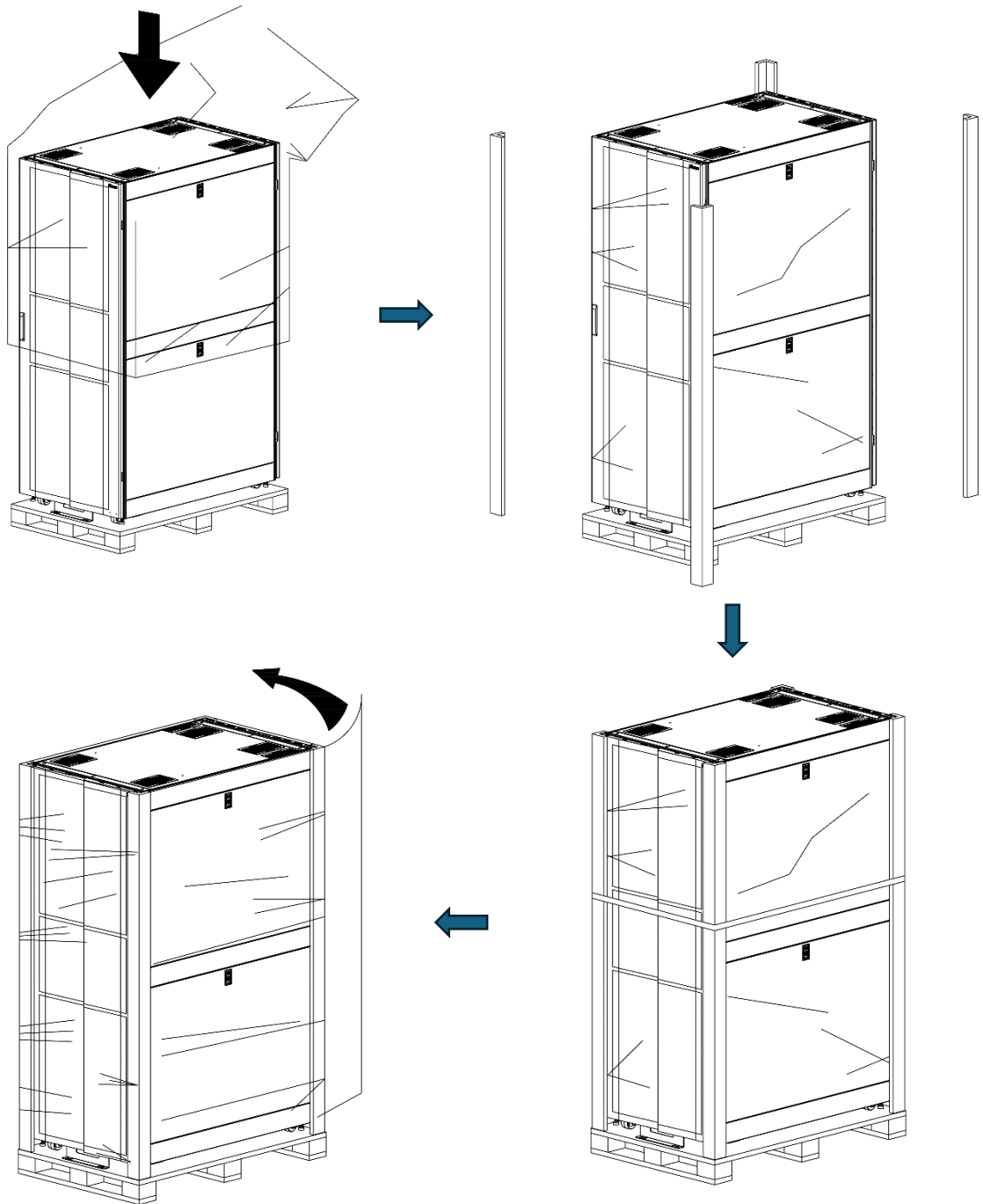
Packing Instructions**NOTE:**

1. Installation on site in the Data Center, the packing part can be ignored.
2. For rack-and-roll application, cabinet needs to stack equipment in-house, and then pack with shock package for transportation, please contact Inova to get shocked package product and packing guidance.